

TUBE CLAMPS Furnished Closed

MATERIAL: CR or HD Galv Steel G90

FINISH: None (Plain), Zinc Plated or Pre-plated

CUSHION: Black Vinyl, 1/32" Thick. We Recommend Vinyl Coated Parts Be Produced With HD Galv Steel G90.

NOTE: CCV-CC Clamps Are Formed Closed – Natural Spring Back Allowed.

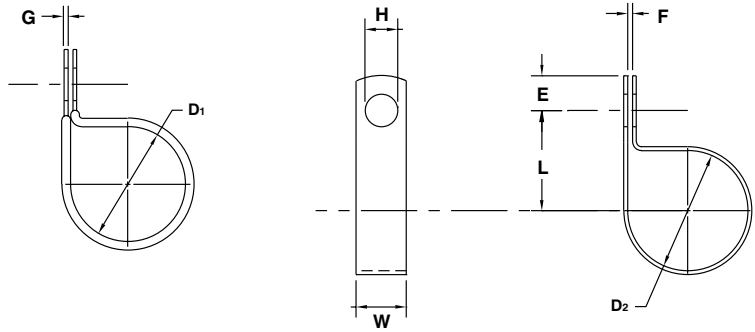

D ₁ Clamping Diameter	Part Number	D ₂ Clamping Diameter	Part Number	H Hole Diameter	L Center To Center	W Width	E Hole Center To End	F Gap	G Gage
±.031		±.015		±.005	±.031	±.010	±.015	±.031	See Pg. 40
		.250	CC-0409	.281	.531	.625	.250	.062	.032
			CC-0411	.343	.594	.625	.312		
			CC-0413	.406	.656	.750	.375		
			CC-0415	.468	.718	.750	.437		
.250	CCV-0509	.312	CC-0509	.281	.562	.625	.250	.062	.032
	CCV-0511		CC-0511	.343	.625	.625	.312		
	CCV-0513		CC-0513	.406	.688	.750	.375		
.312	CCV-0609	.375	CC-0609	.281	.593	.625	.250	.062	.032
	CCV-0611		CC-0611	.343	.656	.625	.312		
	CCV-0613		CC-0613	.406	.718	.750	.375		
	CCV-0615		CC-0615	.468	.781	.750	.437		
	CCV-0617		CC-0617	.531	.843	.875	.500		
.375	CCV-0709	.437	CC-0709	.281	.625	.625	.250	.062	.048
	CCV-0711		CC-0711	.343	.687	.625	.312		
	CCV-0713		CC-0713	.406	.750	.750	.375		
	CCV-0715		CC-0715	.468	.812	.750	.437		
	CCV-0717		CC-0717	.531	.875	.875	.500		
.437	CCV-0809	.500	CC-0809	.281	.687	.625	.250	.062	.048
	CCV-0811		CC-0811	.343	.750	.625	.312		
	CCV-0813		CC-0813	.406	.812	.750	.375		
	CCV-0815		CC-0815	.468	.875	.875	.437		
	CCV-0817		CC-0817	.531	.937	1.000	.500		
.500	CCV-0909	.562	CC-0909	.281	.718	.625	.250	.062	.048
	CCV-0911		CC-0911	.343	.781	.625	.312		
	CCV-0913		CC-0913	.406	.843	.750	.375		
	CCV-0915		CC-0915	.468	.906	.875	.437		
	CCV-0917		CC-0917	.531	.968	1.000	.500		
.562	CCV-1009	.625	CC-1009	.281	.750	.625	.250	.062	.048
	CCV-1011		CC-1011	.343	.812	.625	.312		
	CCV-1013		CC-1013	.406	.875	.750	.375		
	CCV-1015		CC-1015	.468	.937	.875	.437		
	CCV-1017		CC-1017	.531	1.000	1.000	.500		
.625	CCV-1109	.687	CC-1109	.281	.781	.625	.250	.062	.048
	CCV-1111		CC-1111	.343	.843	.625	.312		
	CCV-1113		CC-1113	.406	.906	.750	.375		
	CCV-1115		CC-1115	.468	.968	.875	.437		
	CCV-1117		CC-1117	.531	1.031	1.000	.500		

Except for clamping diameter, dimensions of cushioned and plain parts are identical.

TUBE CLAMPS Furnished Closed

MATERIAL: CR or HD Galv Steel G90

FINISH: None (Plain), Zinc Plated or Pre-plated

CUSHION: Black Vinyl, 1/32" Thick. We Recommend Vinyl Coated Parts Be Produced With HD Galv Steel G90.

NOTE: CCV-CC Clamps Are Formed Closed – Natural Spring Back Allowed.

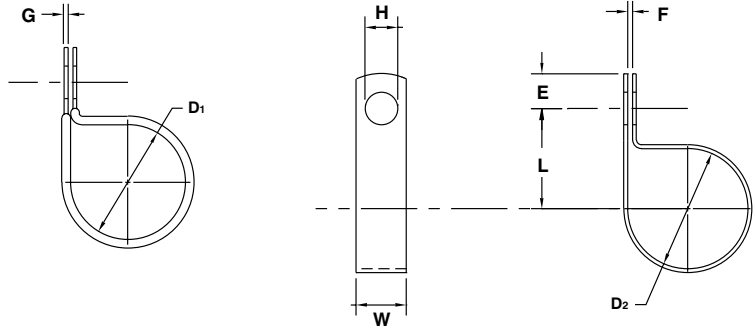
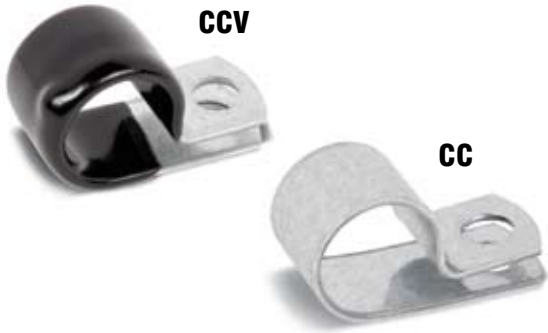

D ₁	Part Number	D ₂	Part Number	H	L	W	E	F	G
Clamping Diameter		Clamping Diameter		Hole Diameter	Center To Center	Width	Hole Center To End	Gap	Gage
±.031		±.015		±.005	±.031	±.010	±.015	±.031	See Pg. 40
.687	CCV-1209	.750	CC-1209	.281	.843	.625	.250	.062	.060
	CCV-1211		CC-1211	.343	.906	.625	.312		
	CCV-1213		CC-1213	.406	.968	.750	.375		
	CCV-1215		CC-1215	.468	1.031	.875	.437		
	CCV-1217		CC-1217	.531	1.093	1.000	.500		
.750	CCV-1309	.812	CC-1309	.281	.906	.625	.250	.062	.060
	CCV-1311		CC-1311	.343	.968	.625	.312		
	CCV-1313		CC-1313	.406	1.031	.750	.375		
	CCV-1315		CC-1315	.468	1.093	.875	.437		
	CCV-1317		CC-1317	.531	1.156	1.000	.500		
.812	CCV-1409	.875	CC-1409	.281	.937	.625	.250	.062	.060
	CCV-1411		CC-1411	.343	1.000	.625	.312		
	CCV-1413		CC-1413	.406	1.062	.750	.375		
	CCV-1415		CC-1415	.468	1.125	.875	.437		
	CCV-1417		CC-1417	.531	1.187	1.000	.500		
.875	CCV-1509	.937	CC-1509	.281	1.000	.625	.250	.062	.060
	CCV-1511		CC-1511	.343	1.062	.625	.312		
	CCV-1513		CC-1513	.406	1.125	.750	.375		
	CCV-1515		CC-1515	.468	1.187	.875	.437		
	CCV-1517		CC-1517	.531	1.250	1.000	.500		
.937	CCV-1609	1.000	CC-1609	.281	1.062	.625	.250	.062	.060
	CCV-1611		CC-1611	.343	1.125	.750	.312		
	CCV-1613		CC-1613	.406	1.187	.750	.375		
	CCV-1615		CC-1615	.468	1.250	.875	.437		
	CCV-1617		CC-1617	.531	1.312	1.000	.500		
1.000	CCV-1709	1.062	CC-1709	.281	1.125	.625	.250	.062	.060
	CCV-1711		CC-1711	.343	1.187	.750	.312		
	CCV-1713		CC-1713	.406	1.250	.750	.375		
	CCV-1715		CC-1715	.468	1.312	.875	.437		
	CCV-1717		CC-1717	.531	1.375	1.000	.500		

Except for clamping diameter, dimensions of cushioned and plain parts are identical.

TUBE CLAMPS Furnished Closed

MATERIAL: CR or HD Galv Steel G90

FINISH: None (Plain), Zinc Plated or Pre-plated

CUSHION: Black Vinyl, 1/32" Thick. We Recommend Vinyl Coated Parts Be Produced With HD Galv Steel G90.

NOTE: CCV-CC Clamps Are Formed Closed – Natural Spring Back Allowed.

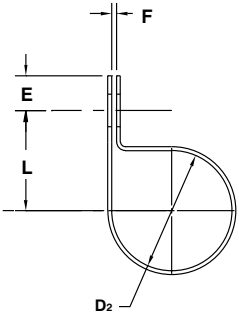
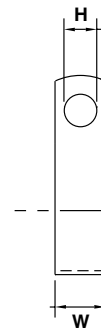
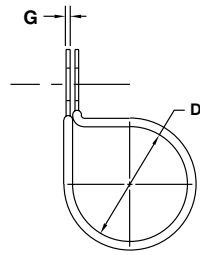

D ₁ Clamping Diameter ±.031	Part Number	D ₂ Clamping Diameter ±.015	Part Number	H Hole Diameter ±.005	L Center To Center ±.031	W Width ±.010	E Hole Center To End ±.015	F Gap ±.031	G Gage See Pg. 40
1.062	CCV-1809	1.125	CC-1809	.281	1.156	.625	.250	.093	.060
	CCV-1811		CC-1811	.343	1.218	.750	.312		
	CCV-1813		CC-1813	.406	1.281	.750	.375		
	CCV-1815		CC-1815	.468	1.343	.875	.437		
	CCV-1817		CC-1817	.531	1.406	1.000	.500		
1.125	CCV-1911	1.187	CC-1911	.343	1.250	.750	.312	.093	.060
	CCV-1913		CC-1913	.406	1.312	.750	.375		
	CCV-1915		CC-1915	.468	1.375	.875	.437		
	CCV-1917		CC-1917	.531	1.437	1.000	.500		
1.187	CCV-2011	1.250	CC-2011	.343	1.281	.750	.437	.093	.060
	CCV-2013		CC-2013	.406	1.343	.750	.500		
	CCV-2015		CC-2015	.468	1.406	.875	.500		
	CCV-2017		CC-2017	.531	1.468	1.000	.562		
1.250	CCV-2111	1.312	CC-2111	.343	1.312	.750	.437	.093	.060
	CCV-2113		CC-2113	.406	1.375	.750	.500		
	CCV-2115		CC-2115	.468	1.437	.875	.500		
	CCV-2117		CC-2117	.531	1.500	1.000	.562		
1.312	CCV-2211	1.375	CC-2211	.343	1.343	.750	.437	.093	.060
	CCV-2213		CC-2213	.406	1.406	.750	.500		
	CCV-2215		CC-2215	.468	1.468	.875	.500		
	CCV-2217		CC-2217	.531	1.531	1.000	.562		
1.375	CCV-2311	1.437	CC-2311	.343	1.375	.750	.437	.093	.060
	CCV-2313		CC-2313	.406	1.437	.750	.500		
	CCV-2315		CC-2315	.468	1.500	.875	.500		
	CCV-2317		CC-2317	.531	1.562	1.000	.562		
1.437	CCV-2411	1.500	CC-2411	.343	1.437	.750	.437	.093	.060
	CCV-2413		CC-2413	.406	1.500	.750	.500		
	CCV-2415		CC-2415	.468	1.562	.875	.500		
	CCV-2417		CC-2417	.531	1.625	1.000	.562		
1.500	CCV-2511	1.562	CC-2511	.343	1.468	.750	.437	.125	.060
	CCV-2513		CC-2513	.406	1.531	.750	.500		
	CCV-2515		CC-2515	.468	1.593	.875	.500		
	CCV-2517		CC-2517	.531	1.656	1.000	.562		

Except for clamping diameter, dimensions of cushioned and plain parts are identical.

HEAVY DUTY CLAMPS

TUBE CLAMPS Furnished Closed

MATERIAL: CR or HD Galv Steel G90

FINISH: None (Plain), Zinc Plated or Pre-plated

CUSHION: Black Vinyl, 1/32" Thick. We Recommend Vinyl Coated Parts Be Produced With HD Galv Steel G90.

NOTE: CCV-CC Clamps Are Formed Closed – Natural Spring Back Allowed.

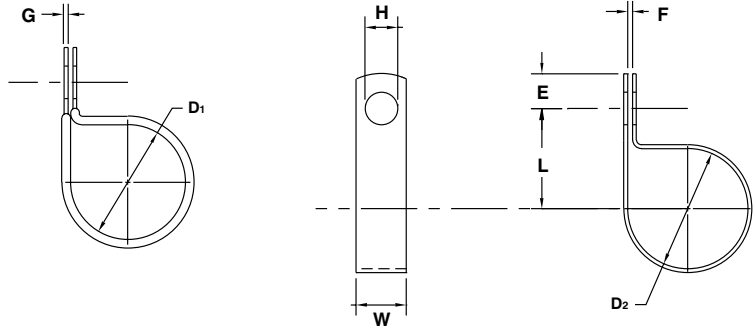

D ₁	Part Number	D ₂	Part Number	H	L	W	E	F	G
Clamping Diameter		Clamping Diameter		Hole Diameter	Center To Center	Width	Hole Center To End	Gap	Gage
±.031		±.015		±.005	±.031	±.010	±.015	±.031	See Pg. 40
1.562	CCV-2611	1.625	CC-2611	.343	1.500	.750	.437	.125	.060
	CCV-2613		CC-2613	.406	1.562	.750	.500		
	CCV-2615		CC-2615	.468	1.625	.875	.500		
	CCV-2617		CC-2617	.531	1.687	1.000	.562		
1.625	CCV-2711	1.687	CC-2711	.343	1.531	.750	.437	.125	.060
	CCV-2713		CC-2713	.406	1.593	.750	.500		
	CCV-2715		CC-2715	.468	1.656	.875	.500		
	CCV-2717		CC-2717	.531	1.718	1.000	.562		
1.687	CCV-2811	1.750	CC-2811	.343	1.562	.750	.437	.125	.060
	CCV-2813		CC-2813	.406	1.625	.750	.500		
	CCV-2815		CC-2815	.468	1.687	.875	.500		
	CCV-2817		CC-2817	.531	1.750	1.000	.562		
1.750	CCV-2911	1.812	CC-2911	.343	1.625	.750	.437	.125	.060
	CCV-2913		CC-2913	.406	1.687	.750	.500		
	CCV-2915		CC-2915	.468	1.750	.875	.500		
	CCV-2917		CC-2917	.531	1.812	1.000	.562		
1.812	CCV-3011	1.875	CC-3011	.343	1.656	.750	.437	.125	.060
	CCV-3013		CC-3013	.406	1.718	.750	.500		
	CCV-3015		CC-3015	.468	1.781	.875	.500		
	CCV-3017		CC-3017	.531	1.843	1.000	.562		
1.875	CCV-3111	1.937	CC-3111	.343	1.687	.750	.437	.125	.060
	CCV-3113		CC-3113	.406	1.750	.750	.500		
	CCV-3115		CC-3115	.468	1.812	.875	.500		
	CCV-3117		CC-3117	.531	1.875	1.000	.562		
1.937	CCV-3211	2.000	CC-3211	.343	1.781	.750	.437	.125	.060
	CCV-3213		CC-3213	.406	1.843	.750	.500		
	CCV-3215		CC-3215	.468	1.906	.875	.500		
	CCV-3217		CC-3217	.531	1.968	1.000	.562		
2.000	CCV-3311	2.062	CC-3311	.343	1.812	.750	.437	.125	.060
	CCV-3313		CC-3313	.406	1.875	.750	.500		
	CCV-3315		CC-3315	.468	1.937	.875	.500		
	CCV-3317		CC-3317	.531	2.000	1.000	.562		

Except for clamping diameter, dimensions of cushioned and plain parts are identical.